

TOSHIBA

MULTIFUNCTIONAL DIGITAL SYSTEMS

Software Installation Guide

e-STUDIO2523A/2523AD

e-STUDIO2323AM/2823AM

Preface

Thank you for purchasing Toshiba Multifunctional Digital Systems. This manual explains how to install client software. Read this manual before use. Keep this manual within easy reach, and use it to configure an environment that makes best use of the e-STUDIO's functions.

■ How to read this manual

□ Symbols in this manual

In this manual, some important items are described with the symbols shown below. Be sure to read these items before using this equipment.

 **WARNING** Indicates a potentially hazardous situation which, if not avoided, could result in death, serious injury, or serious damage, or fire in the equipment or surrounding objects.

 **CAUTION** Indicates a potentially hazardous situation which, if not avoided, may result in minor or moderate injury, partial damage to the equipment or surrounding objects, or loss of data.

 **Note** Indicates information to which you should pay attention when operating the equipment.

 **Tip** Describes handy information that is useful to know when operating the equipment.

 Pages describing items related to what you are currently doing. See these pages as required.

□ Screens and Operation Procedures

In this manual, the screens and the operation procedures in Windows are described for Windows 10. The details on the screens may differ depending on how the equipment is used, such as the status of the installed options, the OS version and the applications.

□ Trademarks

For trademarks, refer to the **Safety Information**.

END USER SOFTWARE LICENSE AGREEMENT

INSTALLING OR OTHERWISE USING THIS SOFTWARE PRODUCT CONSTITUTES YOUR ACCEPTANCE OF THE FOLLOWING TERMS AND CONDITIONS (UNLESS A SEPARATE LICENSE IS PROVIDED BY THE SUPPLIER OF APPLICABLE SOFTWARE IN WHICH CASE SUCH SEPARATE LICENSE SHALL APPLY). IF YOU DO NOT ACCEPT THESE TERMS, YOU MAY NOT INSTALL OR USE THIS SOFTWARE, AND YOU MUST PROMPTLY RETURN THE SOFTWARE TO THE LOCATION WHERE YOU OBTAINED IT.

GRANT OF LICENSE:

This is a legal agreement between you, the end-user (“You”), and TOSHIBA TEC Corporation (“TTEC”). This software, fonts (including their typefaces) and related documentation (“Software”) is licensed for use with TTEC MFP on which it was installed to the designated device you use (“System”) in accordance with the terms contained in this License Agreement. The copyright and other intellectual property rights, title and ownership of Software is proprietary and belonging to TTEC **and its suppliers**. TTEC disclaim responsibility for the installation and/or use of Software, and for the results obtained by using Software. You may use one copy of Software as installed on a single System, and may not copy Software for any reason except as necessary to use Software on a single System. Any copies of Software shall be subject to the conditions of this License Agreement. You may not, nor cause or permit any third party to, modify, adapt, merge, translate, reverse compile, reverse assemble, or reverse engineer Software. You may not use Software, except in accordance with this license. No title to the intellectual property in Software is transferred to you and full ownership is retained by TTEC **and its suppliers**. Source code of Software is not licensed to you. You may not perform modification, deletion, etc to the copyright notice of Software (including in duplicate). You will be held legally responsible for any copyright infringement, unauthorized transfer, reproduction or use of Software.

TERM:

This license is effective until terminated by TTEC or upon your failure to comply with any term of this License Agreement. Upon termination, you agree to destroy all copies of Software. You may terminate this license at any time by destroying Software and all copies.

DISCLAIMER OF WARRANTY:

Software is provided “AS IS” without warranty of any kind, either express or implied, including, but not limited to, the implied warranties of merchantability, fitness for a particular purpose, title, and non-infringement. TTEC disclaims any warranty relating to the quality and performance of Software. If Software proves defective, You (and not TTEC) shall be responsible for the entire cost of all necessary servicing, repair or correction. TTEC does not warrant that the functions contained in Software will meet your requirements or that the operation of Software will be uninterrupted or error free.

UPDATE AND DISCONTINUE:

TTEC may update, upgrade and discontinue Software without any restriction.

THIRD PARTY SOFTWARE:

There are cases in which third party software is contained in Software (including future updated and upgraded versions). Such third party software is provided to you on different terms from those of this License Agreement, in the form of term stated in the License Agreement with the suppliers or the readme files (or files similar to readme files) separately from this License Agreement (“Separate Agreements, etc.”). When you use the third party software, you must comply with the term of the third party software stated in the Separate Agreements, etc. Except the term of the third party software, you must comply with the term stated in this License Agreement.

LIMITATION OF LIABILITY:

IN NO EVENT WILL TTEC BE LIABLE TO YOU FOR ANY DAMAGES, WHETHER IN CONTRACT, TORT, OR OTHERWISE (except personal injury or death resulting from negligence on the part of TTEC), INCLUDING WITHOUT LIMITATION ANY LOST PROFITS, LOST DATA, LOST SAVINGS OR OTHER INCIDENTAL, SPECIAL OR CONSEQUENTIAL DAMAGES ARISING OUT OF THE USE OR INABILITY TO USE SOFTWARE, EVEN IF TTEC OR ITS SUPPLIERS HAVE BEEN ADVISED OF THE POSSIBILITY OF SUCH DAMAGES, NOR FOR THIRD PARTY CLAIMS.

U.S. GOVERNMENT RESTRICTED RIGHTS:

The Software is provided with RESTRICTED RIGHTS. Use, duplication or disclosure by the U.S. Government is subject to restrictions set forth in subdivision (b)(3)(ii) or (c)(i)(ii) of the Rights in Technical Data and Computer Software Clause set forth in 252.227-7013, or 52.227-19 (c)(2) of the DOD FAR, as appropriate.

GENERAL:

You may not sublicense, lease, rent, assign or transfer this license or Software. Any attempt to sublicense, lease, rent, assign or transfer any of the rights, duties or obligations hereunder is void. You agree that you do not intend to, and will not ship, transmit, export or re-export (directly or indirectly) Software, including any copies of Software, or any technical information contained in Software or its media, or any direct product thereof, to any country or destination prohibited by government of Japan, the United States and the relevant country. This license shall be governed by the laws of Japan or, at the election of a Supplier of TTEC concerned with a dispute arising from or relating to this Agreement, the laws of the Country designated from time to time by the relevant Supplier of TTEC. If any provision or portion of this License Agreement shall be found to be illegal, invalid or unenforceable, the remaining provisions or portions shall remain in full force and effect.

YOU ACKNOWLEDGE THAT YOU HAVE READ THIS LICENSE AGREEMENT AND THAT YOU UNDERSTAND ITS PROVISIONS. YOU AGREE TO BE BOUND BY ITS TERMS AND CONDITIONS. YOU FURTHER AGREE THAT THIS LICENSE AGREEMENT CONTAINS THE COMPLETE AND EXCLUSIVE AGREEMENT BETWEEN YOU AND TTEC AND ITS SUPPLIERS AND SUPERSEDES ANY PROPOSAL OR PRIOR AGREEMENT, ORAL OR WRITTEN, OR ANY OTHER COMMUNICATION RELATING TO THE SUBJECT MATTER OF THIS LICENSE AGREEMENT.

Contractor/Manufacturer is TOSHIBA TEC Corporation, 1-11-1, Osaki, Shinagawa-ku, Tokyo, 141-8562, Japan

CONTENTS

Preface	3
END USER SOFTWARE LICENSE AGREEMENT	4

Chapter 1 BEFORE INSTALLATION

Before Installation	10
Software on the Client Utilities/User Documentation DVD	10
System requirements	10

Chapter 2 INSTALLING DRIVERS

Installing Drivers	12
USB connection	12
Network connection	12
Installing the drivers	13
Uninstalling the Drivers	19

INDEX	21
--------------------	-----------

1

BEFORE INSTALLATION

Before you start the installation, refer to the following pages.

Before Installation	10
Software on the Client Utilities/User Documentation DVD	10
System requirements	10

Before Installation

This section helps you to plan an installation suited to your environment.

■ Software on the Client Utilities/User Documentation DVD

- **Printer driver**
Allows you to use this equipment as a printer when it is connected to a Windows computer.
- **Scanner driver**
Allows you to scan the originals set in this equipment remotely from your Windows computer and send the image to a TWAIN-compliant application.
- **e-STUDIO Scan Editor**
Allows you to scan the original set in this equipment from your Windows computer and edit the scanned images simply.

■ System requirements

- **CPU**
1 GHz minimum (1 GHz or faster recommended)
- **Memory**
32-bit processor
 - 1 GB (2 GB recommended)64-bit processor
 - 2 GB (4 GB recommended)
- **Interface**
USB 2.0 (Hi-Speed)
- **OS**
Windows 7 SP1
Windows 8.1
Windows 10
Windows Server 2008 SP2
Windows Server 2008 R2 SP1
Windows Server 2012
Windows Server 2012 R2
Windows Server 2016

INSTALLING DRIVERS

This chapter explains the installation in Windows.

Installing Drivers	12
USB connection	12
Network connection	12
Installing the drivers	13
Uninstalling the Drivers	19

Installing Drivers

This equipment and the computer can be connected with a USB cable or via a network. (Connection via a network is available only for e-STUDIO2323AM/2823AM.)

■ USB connection

Before installing the drivers, connect the equipment and the computer with a USB cable, and turn the power ON.

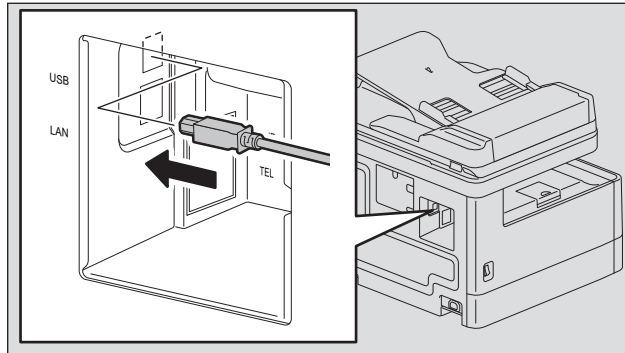

■ Network connection

Before installing the drivers, connect the equipment to the network, and then turn on the equipment.

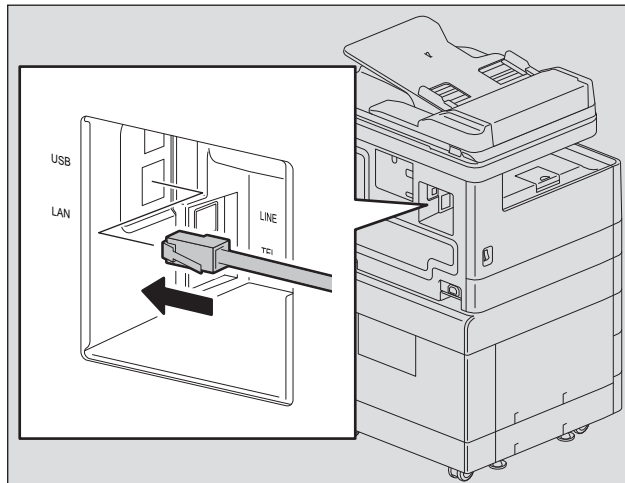

■ Installing the drivers

Install the drivers using the installer or the Windows Plug and Play function.

Note

- Close any running software, such as an antivirus program, before installing the drivers.
- For Windows 7, Windows 8.1, Windows 10, Windows Server 2008 R2, Windows Server 2012, or Windows Server 2016, use the installer to install the drivers. The Windows Plug and Play function cannot install them.
📖 P.13 “Installing the drivers using the installer (for e-STUDIO2523A/2523AD)”

❑ Installing the drivers using the installer (for e-STUDIO2523A/2523AD)

- 1 Make sure that the equipment is turned on.**
- 2 Insert the Client Utilities/User Documentation DVD into your computer.**
 - The installer automatically starts and opens the installation dialog box.
 - If the installer does not automatically start, open the “Drivers” folder and double-click “Setup.exe” in the DVD.
- 3 Select “I accept the terms of the license agreement” and click [Next].**
- 4 Check the software to install and click [Next].**
- 5 Click [Finish] when the installation is complete.**

To install e-STUDIO Scan Editor, open the [Application] - [e-STUDIO Scan Editor] folders, double-click “eSScanSetup.exe”, and follow the instructions that appear on the screen. After the installation, remove the DVD from the computer.

Tip

The Installer may ask you to restart your computer. If it does, select “Yes, I want to restart my computer now.” to restart your computer.

❑ Installing the drivers using the installer (for e-STUDIO2323AM/2823AM)

- 1 Make sure that the equipment is turned on.**
- 2 Insert the Client Utilities/User Documentation DVD into your computer.**
 - The installer automatically starts and opens the installation dialog box.
 - If the installer does not automatically start, open the “Drivers” folder and double-click “Setup.exe” in the DVD.
- 3 Select “I accept the terms of the license agreement” and click [Next].**
- 4 Select [USB Connection] or [Network Connection], and then click [Next].**
- 5 Make sure that the equipment has been connected to the computer or the network and click [Next].**

If you have selected [USB Connection] at the previous step, proceed to step 7.

6 Check the detected printer, select the model and click [Next].

Note

If the equipment is not discovered over the network, specify the IP address manually following the steps below. For the IP address of the equipment, refer to *User's Guide* “**Chapter 5: VARIOUS FUNCTIONS - Network Menu List - Setting the TCP/IP protocol**”.

1. Click [Back].

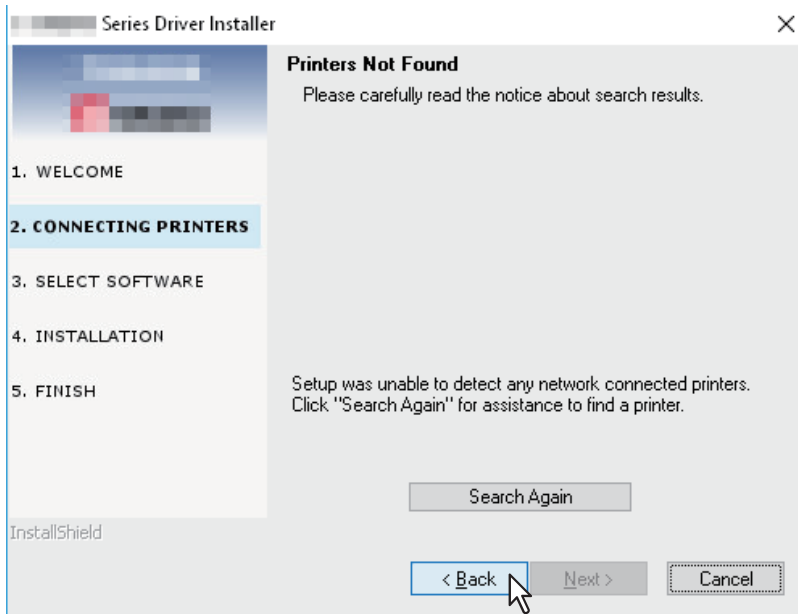

2. Select [Select if you want to set the printer's IP Address manually.], and then click [Next].

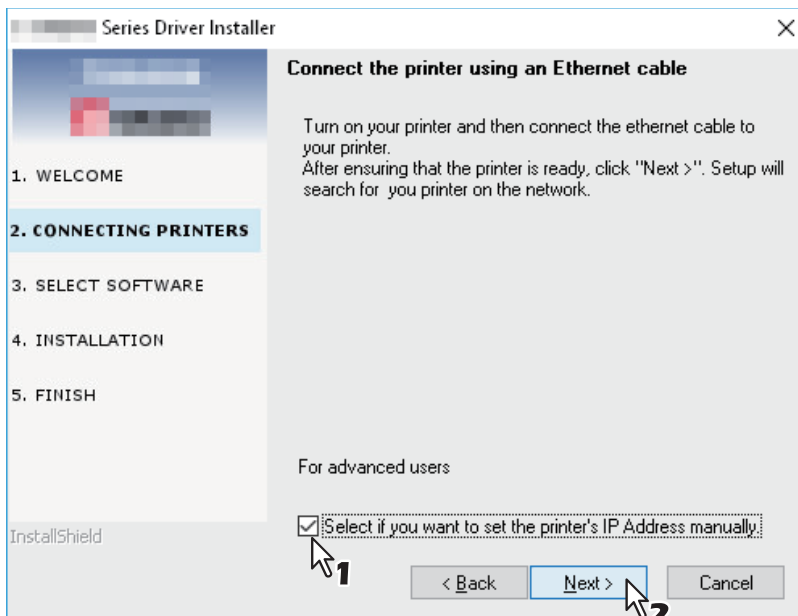

3. Enter the IP address of the equipment under [Specify a network printer by host name of IP address.], then click [Next].

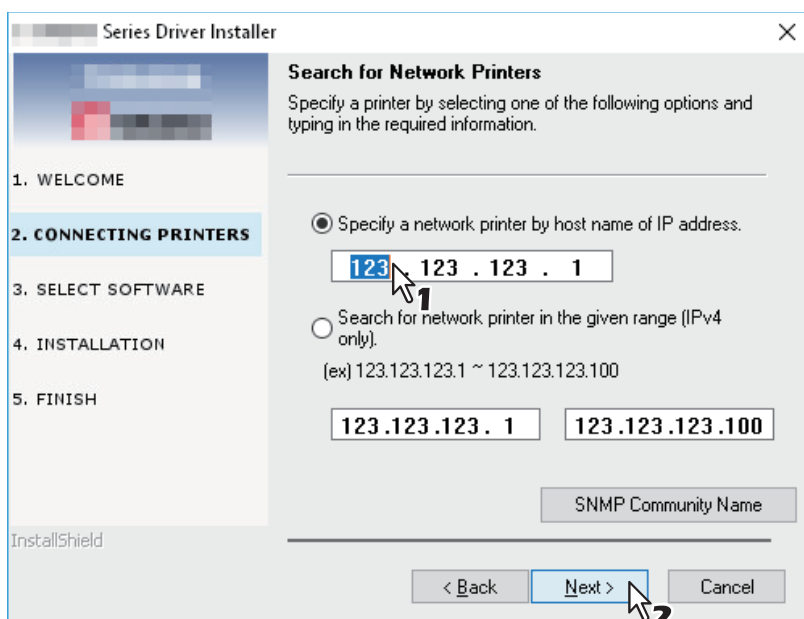

7 Check the model and the software to install and click [Next].

Note

A scanner driver for the network connection cannot be installed in this equipment. Install a scanner driver for the USB connection.

8 Click [Finish] when the installation is complete.

To install e-STUDIO Scan Editor, open the [Application] - [e-STUDIO Scan Editor] folders, double-click “eSScanSetup.exe”, and follow the instructions that appear on the screen. After the installation, remove the DVD from the computer.

Tip

The Installer may ask you to restart your computer. If it does, select “Yes, I want to restart my computer now.” to restart your computer.

❑ Installing the drivers using Plug and Play

You can use the Windows Plug and Play function to install the drivers in Windows Server 2008. When using Plug and Play, first the scanner driver is installed, and then the printer driver.

Note

For Windows 7, Windows 8.1, Windows 10, Windows Server 2008 R2, Windows Server 2012, or Windows Server 2016, use the installer to install the drivers. The Windows Plug and Play function cannot install them.

📖 P.13 “Installing the drivers using the installer (for e-STUDIO2523A/2523AD)”

Tip

An additional printer wizard can also be used to install the printer driver. To use the additional printer wizard, select the USB port that the equipment is connected to using “Choose a Printer Port”.

1 Connect this equipment to the computer using a USB cable, and then start the computer.

Note

Do not connect or disconnect the USB cable when starting up the computer.

2 Turn on the equipment.

The Found New Hardware dialog box appears.

If it does not appear, turn off this equipment, and then wait approximately 10 seconds before turning it on again. If you turn this equipment on immediately after turning it off, it may not function correctly.

3 Click “Locate and install driver software (recommended)”.

The dialog box requesting the disk (Client Utilities/User Documentation DVD) appears.



If the User Account Control dialog box appears, click [Allow] or [Continue].

4 Click “I don’t have the disc. Show me other options”.

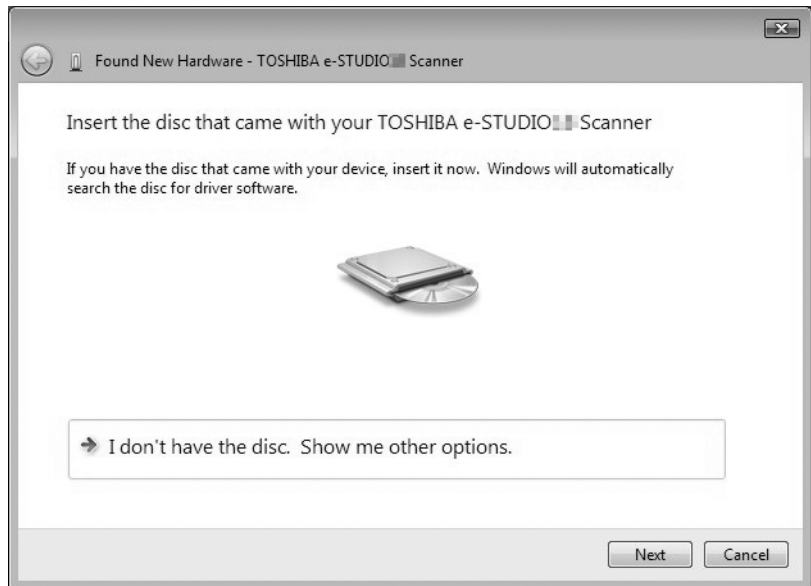

5 Insert the Client Utilities/User Documentation DVD into the computer.

6 Click “Browse my computer for driver software (advanced)”.

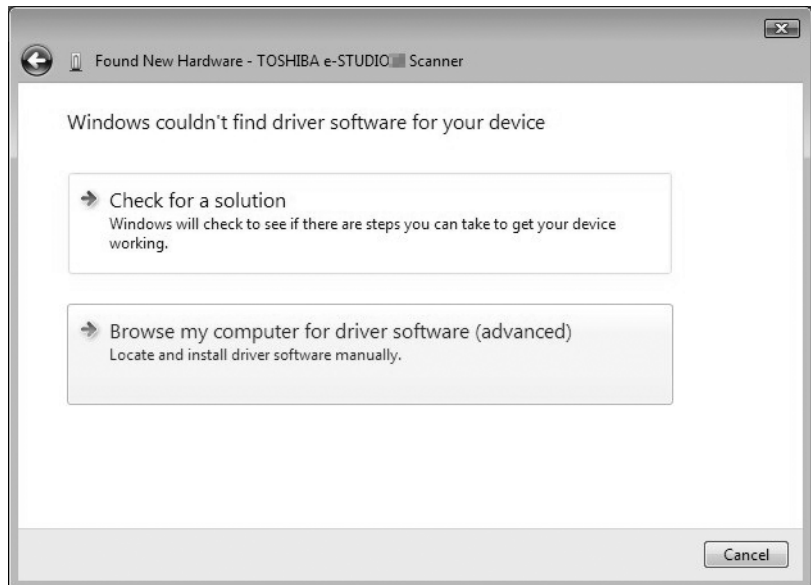

7 Select the folder on the DVD that contains the drivers, and then click [OK].

Select the folder according to the driver, language and operating system you are using. For example, for a 32-bit English OS with a scanner driver, select “Drive name:\Drivers\e-STUDIOXXXXX\e-STUDIOXXXXXSeries\SCANNER\English|i386”.

8 Click [Next].

If the Windows Security dialog box appears, click [Install this driver software anyway].

Note

If a message prompting you to confirm the device software installation appears, select the option of trusting the publisher such as [Install] or [Continue Anyway] to proceed with the installation.

9 When the installation completes, click [Close].

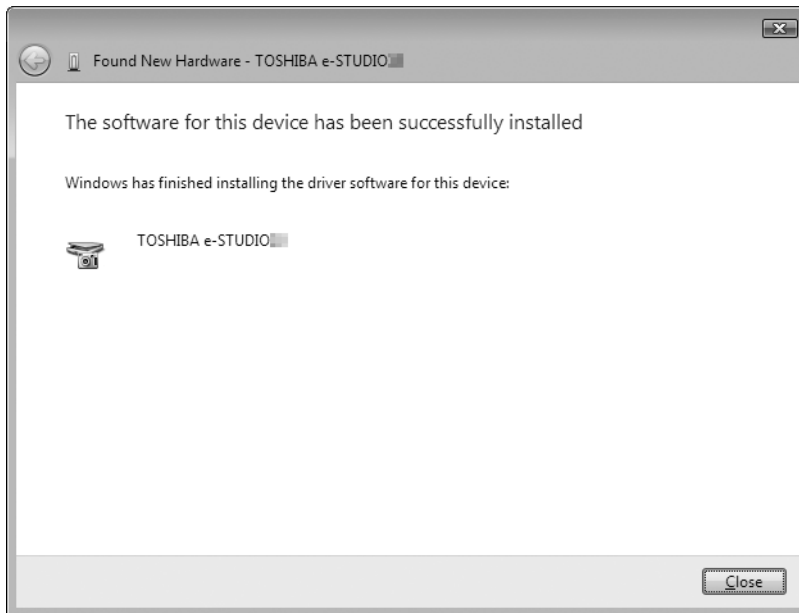

The Found New Hardware dialog box appears again and the installation of the printer driver begins.

- 10** Repeat steps 4 through 9 to install the printer driver.
- 11** After installation, make sure the icon for the installed printer appears in the Printers window.
- 12** Remove the DVD from the computer.

Uninstalling the Drivers

This section explains how to uninstall the printer/scanner drivers and e-STUDIO Scan Editor. Uninstalling the drivers requires the administrator authority.

Note

- To perform uninstallation, you must log onto Windows with the “Administrator” account. However, even if you have logged on with a user account other than “Administrator”, entering an administrator password upon display of the [User Account Control] dialog box enables you to perform the uninstallation by temporarily changing the user account.
- Even when you have logged on Windows with the “Administrator” account, the [User Account Control] dialog box may appear. In this case, click a button for allowing the operation, such as [Continue], and then continue.

Tip

Drivers other than e-STUDIO Scan Editor can be uninstalled from the installer on the DVD, too.

1 Open the [Uninstall a program] folder.

Click [Start], and then click [Windows System] > [Control Panel] > [Uninstall a program] from the list of all applications.

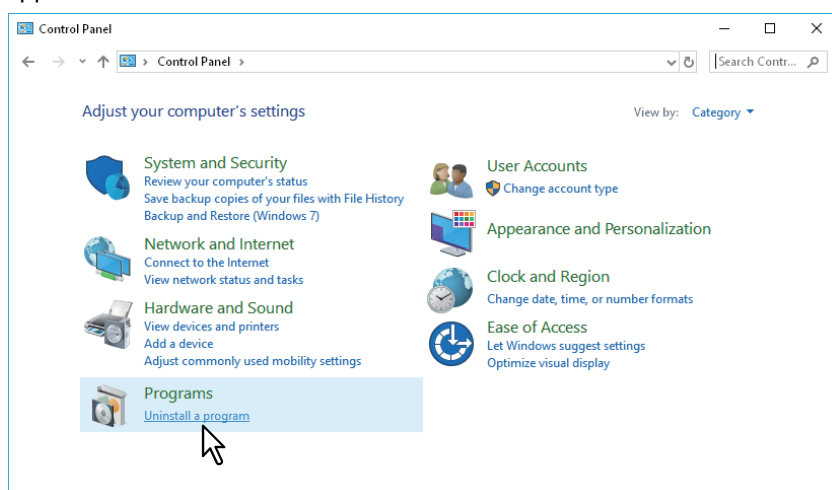

Tip

- Depending on the version of Windows 10, click [Start] and select [All apps], and then select [Windows System]> [Control Panel] > [Uninstall a program] from the list of all applications.
- For Windows 8.1 / Windows Server 2012, from the setting charm, click [Control Panel] > [Uninstall a program].
- For Windows 7 / Windows Server 2008, click [Start] > [Control Panel] > [Uninstall a program].

2 From the list, select you want to uninstall, and click [Uninstall].

3 Click [Yes].

4 Click [Yes] to delete the setting files.

Deleting files starts.

Note

If you want to reinstall the client software later, click [No] to have the setting files remain. You can restore the data and settings when you reinstall the client software.

INDEX

C

Client Utilities/User Documentation DVD..... 10

E

e-STUDIO Scan Editor 10

I

Install 13

Installer..... 13

 Windows..... 13

N

Network connection 12

P

Plug and Play..... 16

Printer driver 10

S

Scanner driver..... 10

System requirements 10

U

Uninstall 19

MULTIFUNCTIONAL DIGITAL SYSTEMS

Software Installation Guide

e-STUDIO2523A/2523AD

e-STUDIO2323AM/2823AM

Toshiba Tec Corporation

1-11-1, OSAKI, SHINAGAWA-KU, TOKYO, 141-8562, JAPAN

©2019 Toshiba Tec Corporation All rights reserved
Patent; <http://www.toshibatec.com/en/patent/>



R180420U7600-TTEC
Ver00 F Issued in May 2019